

UN2.3-12 (12V2.3Ah)



GENERAL FEATURES

- Absorbent Glass Mat (AGM) technology for efficient gas recombination of up to 99% and freedom from electrolyte for air transport-complies with LATA/ICAO Special provision A67.
- Not restricted for air transport-complies with LATA/ICAO Special Provision A67.
- UL-recognized component.
- Can be mounted in any orientation.
- Computer designed lead, calcium tin alloy grid for high power density.
- Long service life, float or cyclic applications,
- Maintenance-free operation.
- Low self discharge.
- Case and cover available in both standard and flame retardant ABS.

SPECIFICATION

Nominal voltage	12V	Dimensions	Total Height	2.64inches(67mm)
Rated capacity (20 hour rate)	2.3Ah		Height	2.4inches(61mm)
Number of cell	6		Length	7.01inches(178mm)
Approx. Weight (Kg /lbs)	0.99/2.18		Width	1.38inches(35mm)

Battery Dimensions

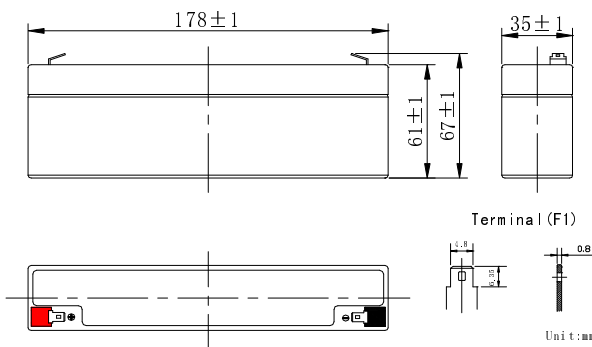

Characteristics

Capacity 77° F (25°C)	20 hour rate (0.115A、10.5V)	2.3Ah
	10 hour rate (0.21A、10.5V)	2.1Ah
	5 hour rate (0.39A、10.5V)	1.95Ah
	1 hour rate (1.4 A、9.6V)	1.4Ah
	1C (2.3A、9.6V)	32min
	3C (6.9A、9.6V)	7min
Internal Resistance	Full charged Battery 77° F (25°C) : 65m Ω	
Capacity affected by Temperature (20 hour rate)	104° F(40°C)	102%
	77° F(25°C)	100%
	32° F(0°C)	85%
	5° F(-15°C)	65%
Self-Discharge 68° F (20°C)	Capacity after 3 month storage	90%
	Capacity after 6 month storage	80%
	Capacity after 12month storage	60%
Max. discharge current 77° F (25°C) : 34. 5A (5S)		
Charge (Constant Voltage)	Float: 13.6~13.8 V/77° F/(25°C)	
	Cycle: 14. 5~14. 9 V/77° F/(25°C) Max. Current: 0.57A	

Constant power discharge ratings-watts per cell at 25°C(77° F)

End Point Volts/Cell	5min	10min	15min	30min	45min	1h	2h	3h	5h
1.60V	17.5	11.0	8.50	4.83	3.50	2.78	1.54	1.08	0.75
1.65V	16.7	10.5	8.14	4.52	3.38	2.46	1.45	1.04	0.74
1.70V	16.0	10.0	7.86	4.28	3.25	2.28	1.35	0.98	0.73
1.75V	15.3	9.46	7.56	4.02	3.11	2.09	1.14	0.93	0.71
1.80V	14.4	8.94	7.24	3.74	3.00	1.86	1.02	0.84	0.62

